

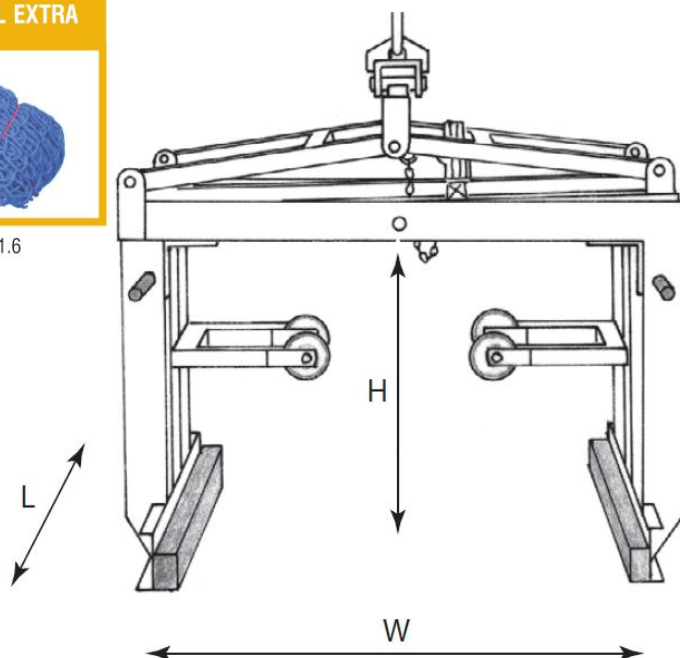

SP10 OPTIONAL EXTRA



Safety net 1.75 x 1.6 x 1.6
SWL 2000 kg



Designed for crane lifting of brick packs and pallets, with adjustable forks. These forks have the advantage of a spring loaded lifting eye which automatically adjusts to compensate for the different weights carried. This ensures that the crane fork stays level, both when empty or full. The load height of these forks can be adjusted from 1100mm to 1600mm by a pin system.

| Code | Cap. (kg) | L | W | H | Wt. (kg) |
|----------|-----------|------|------|------|----------|
| 1083/40 | 1500 | 1100 | 1200 | 400 | 190 |
| 1083/80 | 1800 | 1200 | 1200 | 800 | 200 |
| 1083/100 | 1800 | 1200 | 1200 | 1000 | 220 |

*Lifting & Handling Solutions for the Construction Industry
Designed & Manufactured in the UK*

Conquip Industrial, Waterbrook Estate, Waterbrook Road, Alton, Hampshire, GU34 2UD. United Kingdom
Telephone; +44 (0) 845 201 5030 **Fax;** +44 (0) 845 201 5031 **E-Mail;** sales@conquipindustrial.co.uk